

# Fiberglass Flagpoles

Anchor Base  
Fiberglass  
Internal Halyard  
Flagpoles 25 IAB - 35 IAB

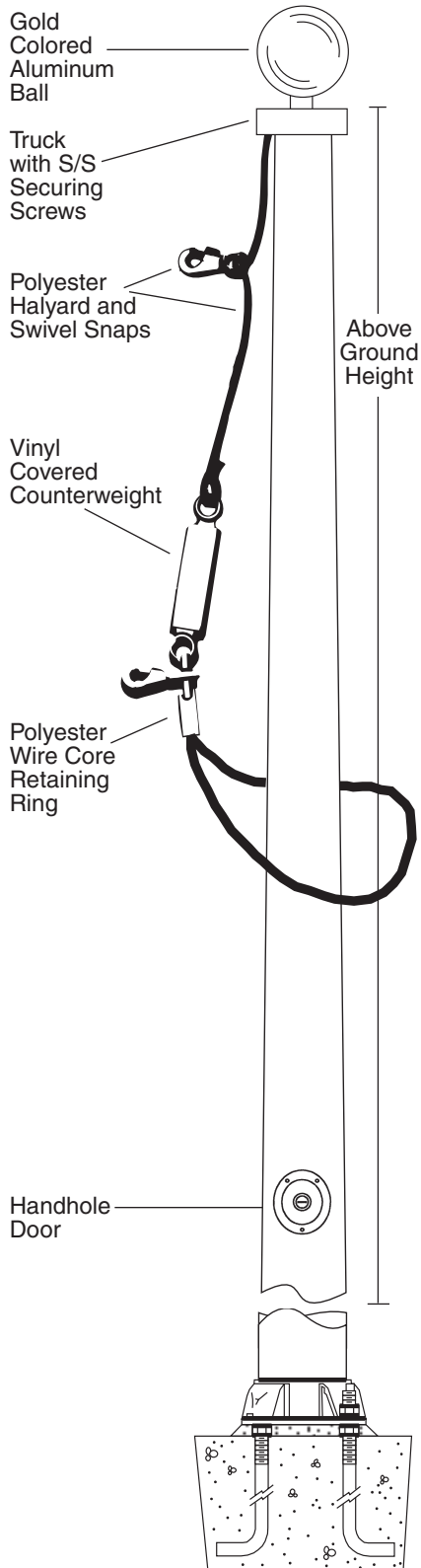

**Fiberglass Stationary Internal Truck**

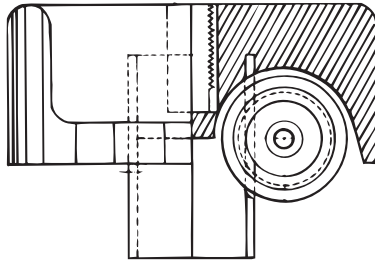

**Internal Cam Cleat and Handhole Door**

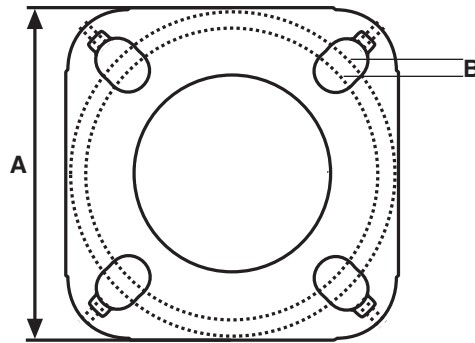
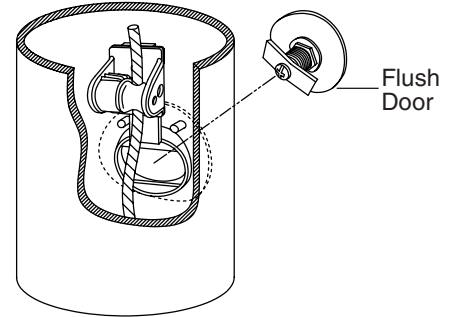

Model Number	PLP 25IAB	PLP 30IAB	PLP 35IAB
Above Ground Height	25'	30'	35'
Butt Diameter	6.5"	6.5"	7"
Top Diameter	3"	3"	3"
Pole Weight With Base (lbs.)	79	94	121
Shipping Weight With Base (lbs.)*	146	170	211
Ball Diameter	5"	6"	6"
Halyard	#10	#10	#10
Truck	F/G	F/G	F/G
Snaps	Brass Swivel	Brass Swivel	Brass Swivel
Standard Flag Size	4x6	5x8	5x8
Anchor Bolt Length	25"	25"	25"
Bolt Diameter	3/4"	3/4"	3/4"
Exposed Thread	2.75"	2.75"	2.75"
Bolt Circle (B)	9"-10"	9"-10"	9"-10"
Base Width (A)	10.24" sq.	10.24" sq.	10.24" sq.

\* Shipping weight includes weight of packaging, fittings, and anchor bolts.

# SPECIFICATIONS

Provide a Fiberglass Reinforced Plastic (FRP) Internal Anchor Base Flagpole Model # \_\_\_\_\_ IAB as manufactured by PLP Composite Technologies, Inc., Fitzwilliam, NH 03447.

The flagpole shall have an overall length of \_\_\_\_\_ feet. The butt diameter shall be \_\_\_\_\_ inches and the top diameter \_\_\_\_\_ inches. The pole weight shall be \_\_\_\_\_ lbs. with a total shipping weight of \_\_\_\_\_ lbs.

The flagpole shall be manufactured of fiberglass woven roving and polyester resin. Load calculations shall be based on AASHTO and NAAMM standards with the pole designed with a two to one safety factor for 120 m.p.h. winds, unflagged.

The flagpole shall have an ENTASIS taper.

The pole shall be sanded smooth and coated with a high gloss UV inhibited finish.

The pole shall be absent of any vertical mold seams.

The color of the flagpole shall be:

Standard white, bronze, black, or other, as specified \_\_\_\_\_. (Select one)

The flagpole shall be equipped with PLP standard fittings:

- A \_\_\_\_\_" gold colored aluminum ball
- A single sheave internal fiberglass stationary truck with stainless steel securing screws
- #10 polyester halyard
- Polyester wire core retaining ring
- Vinyl covered counterweight
- Stainless steel and nylon internal cam cleat
- Handhole door with cylinder cam lock
- Brass swivel snaps with vinyl covers

ANCHOR BASE: Cast Aluminum A356 alloy aluminum, the anchor base shall be heat treated to a T6 condition. The shaft shall be cemented and pinned to a 21" aluminum pipe which shall be inserted into the anchor base casting, and casting and shaft shall be joined by continuous circumferential welds at the outside top and inside bottom of that anchor base.

The base shall be furnished with 4 anchor bolt covers and 4 anchor bolts with 2 nuts, 2 flat washers and 1 lock washer per anchor bolt as follows:

- 3/4" x 25" anchor bolt
- 2 3/4" exposed thread recommended/projection

EXCEPTIONS: \_\_\_\_\_

\_\_\_\_\_

PROJECT: \_\_\_\_\_

LOCATION: \_\_\_\_\_

DATE: \_\_\_\_\_