

Fiberglass Flagpoles

Nautical Single Masted
Flagpole with Yardarm
50' to 60'

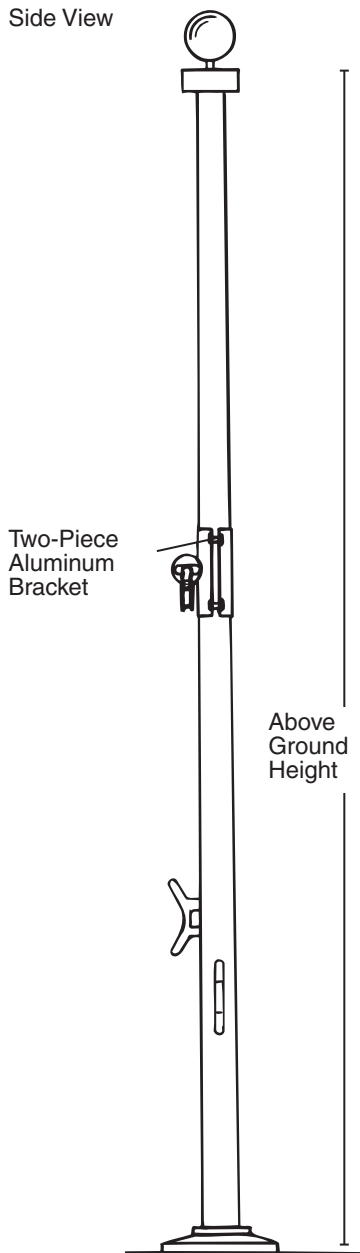

Aluminum Powder Coated Bracket

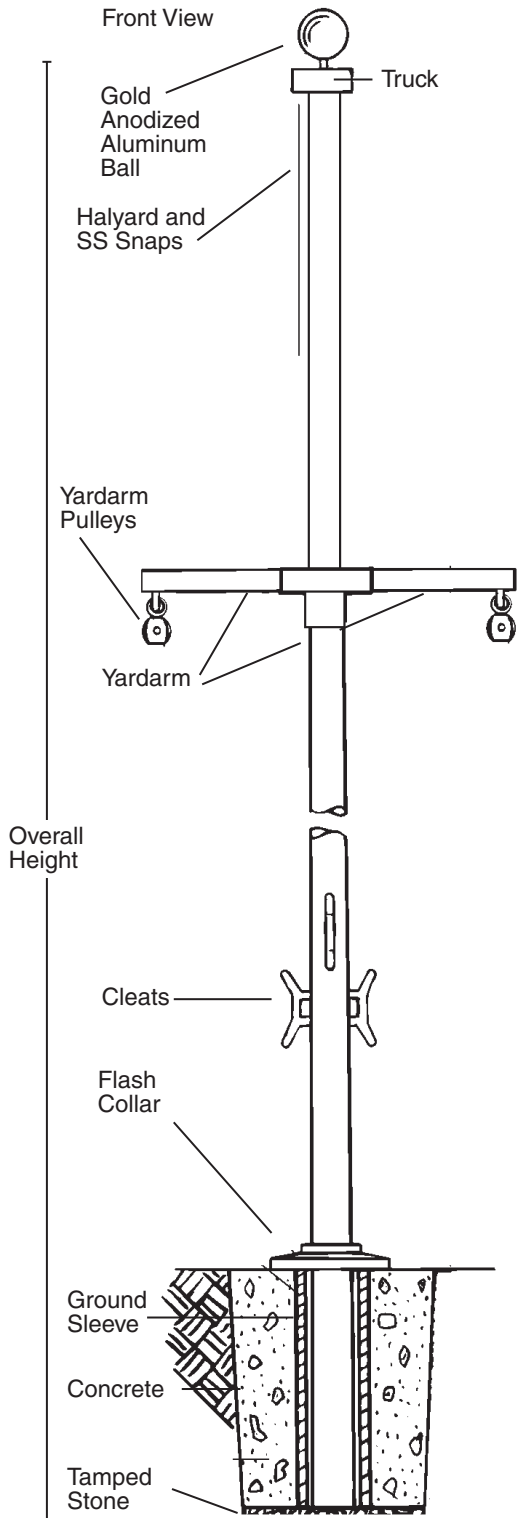
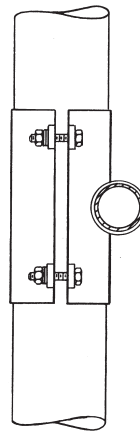

Aluminum Revolving External Truck

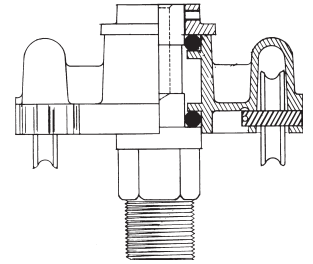

Nautical Single Masted Flagpole with Yardarm 50' to 60'

	50NSM-YA	60NSM-YA
Above Ground Height	50'	60'
Burial Depth	5'	6'
Flagpole		
Overall Length	55'	66'
Top Diameter	4.2"	4.2"
Butt Diameter	10"	10.75"
Burgee	6x10	8x12
Yardarm		
Length	13.5'	16'
End Diameter	3"	3"
Center Diameter	4.5"	4.5"
Standard Flags	6x10	8x12
Ground Sleeve	5' x 14"	6' x 14"
Fittings		
Gold Ball	10"	10"
Truck	ALUM	ALUM
Halyard Size	#12	#12
Cleat (powder coated)	10" AL	10" AL
Snaps (stainless steel)	4.5"	4.5"
Flash Collar	23"	23"
Pole Weight	397	629
Pole Weight (w YA)	442	679
Shipping Weight	648	862
Shipping Weight includes weight of packaging and fittings		

Field Splice Detail

(not to scale)

Poles 50' and 60' are equipped with an internal field splice which is cemented and pinned with stainless pins to the bottom section. The top section simply slides over the self-aligning splice for easy field assembly.

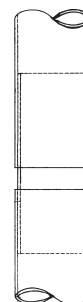

SPECIFICATIONS

Provide a Fiberglass Reinforced Composite (FRC) Flagpole and Yardarm Model # _____ NSM-YA as manufactured by PLP Composite Technologies, Inc., Fitzwilliam, NH 03447.

The flagpole shall have a mounting height of _____' and _____' below grade for an overall length of _____'. It shall have a top diameter of _____" and a butt diameter of _____". The flagpole shall have a total weight of _____ lbs. and a shipping weight of _____ lbs.

The yardarm shall have an overall length of _____'. The diameter at the center of the yardarm shall be _____" and will taper to each end to a diameter of _____". The yardarm shall be secured to the pole shaft with an aluminum powder coated bracket.

The flagpole and yardarm shall be manufactured of fiberglass woven roving and polyester resin with 75% of the reinforcing fibers oriented to the axial plane for maximum stiffness and 25% in the radial plane for required hoop strength. Load calculations shall be based on AASHTO and NAAMM standards designed for 150 m.p.h. winds, unflagged with a 1.3 gust factor.

Both the flagpole and yardarm shall have an ENTASIS taper and shall be void of any vertical mold seams.

The flagpole and yardarm shall be sanded smooth and coated with a high gloss Aliphatic Polyurea coating system which provides UV protection and weatherability.

The color of the flagpole and yardarm shall be: Standard white, black, bronze (select one).

The shaft and yardarm weight shall be _____ lbs. with a shipping weight of _____ lbs.

The flagpole is equipped with:

- A _____" gold anodized aluminum ball
- # _____ polyester halyard
- Powder coated aluminum cleat
- A _____" composite flash collar
- _____' x _____" fiberglass ground sleeve
- Stainless steel swivel snaps/covers
- Revolving external truck

The yardarm is equipped with:

- Yardarm bracket painted to match color of pole (2-piece bracket)
- _____ yardarm pulleys
- # _____ polyester halyards (2 to a set)
- Powder coated aluminum cleats (2 to a set)
- Stainless steel swivel snaps/covers (2 for each side of yardarm)

EXCEPTIONS: _____

PROJECT: _____

LOCATION: _____

DATE: _____

PLP Composite Technologies, Inc.

57 Creamery Road • PO Box 429 • Fitzwilliam, NH 03447 • Tel: 603-585-9100 • Fax: 603-585-3470 • www.plpcomp.com